

Welcome

Thanks for choosing the Sendum PT300D as your Package Tracking solution! The purpose of this Quick Start Guide is to help you get your system up and running as quickly as possible.

Introduction

Your PT300D device (model BFA10107) has been configured for use with either Sprint or Vodafone wireless service.

The service your model is set for will depend on what you specified when you ordered your product. If in doubt, please review your sales order or contact your sales rep.

Step 1: Get Familiar

PT300D Trackers come in many different varieties and configurations. Depending on what you ordered, you may have some, or all, of the components listed in "Figure 1 - PT300D Component List".

To get started working with your new PT300D, at a minimum you will need the PT300D Command Module complete with one of the following:

- a Basic Sensor Pack with the AC Adapter and Data Cable
- an Advanced Sensor Pack with the AC Adapter and Data Cable, OR
- the Accessory Pack, complete with the 10k mAh Battery Pack and Battery Charger

PT300D Command Module

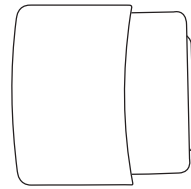

Data Cable

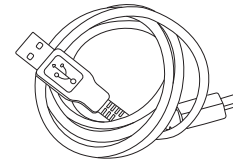

P/N: MCA10017

AC Adapter

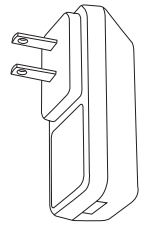

P/N: BFA10069

Basic Sensor Pack

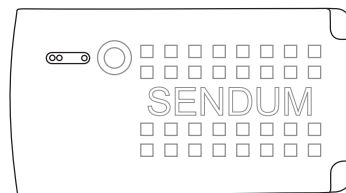

P/N: BFA10062

Advanced Sensor Pack

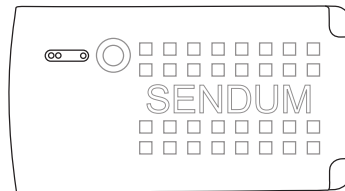

P/N: BFA10063

Accessory Pack

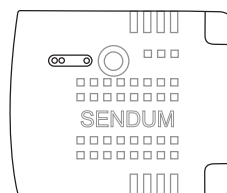

P/N: BFA10077

10k mAh Battery Pack

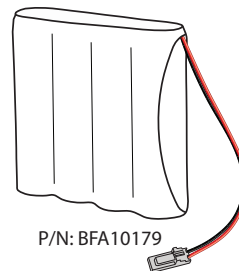

P/N: BFA10179

Battery Charger for 10k mAh Battery

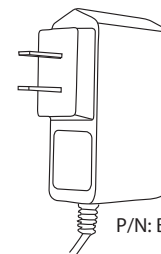

P/N: BFA10095

Figure 1 - PT300D Component List

Step 2: Charging

Just like with any new mobile device, you'll need to charge your battery before you can start using it. This is normally an overnight process, or at least six hours. To do this:

- If you are using either the Basic Sensor Pack or the Advanced Sensor Pack, you can charge it by connecting it to the AC Adapter and then plugging the adapter into any standard electrical receptacle (see "Figure 3 - Charging up a Sensor Pack".)
- If you are using an Accessory Pack with the 10K mAh Battery Pack, the process is similar. Just connect the battery to the AC adapter and then plug the adapter into the electrical receptacle (see "Figure 4 - Charging the 10k mAh Battery Pack".)

Step 3: Airtime Account

In order for your device to operate and communicate properly, you need to have a machine-to-machine (M2M) airtime account set up. If you don't have an account, please contact your wireless provider and provide them the 'Device Identifier' number of your device.

 The Device Identifier is device-specific serial number found on the back of the PT300D Command Module (see "Figure 2 - Locating the PT300D Device ID"). This identifier is also known as ESN, MEID, or IMEI.

What's needed is an M2M airtime account with SMS texting capability. Typical data plan sizes are 1 MB, 5 MB, and 10 MB (with the 5 MB plan being a popular choice).

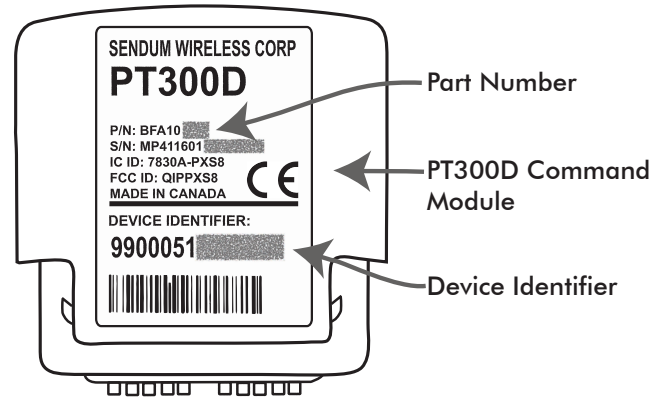

Figure 2 - Locating the PT300D Device ID

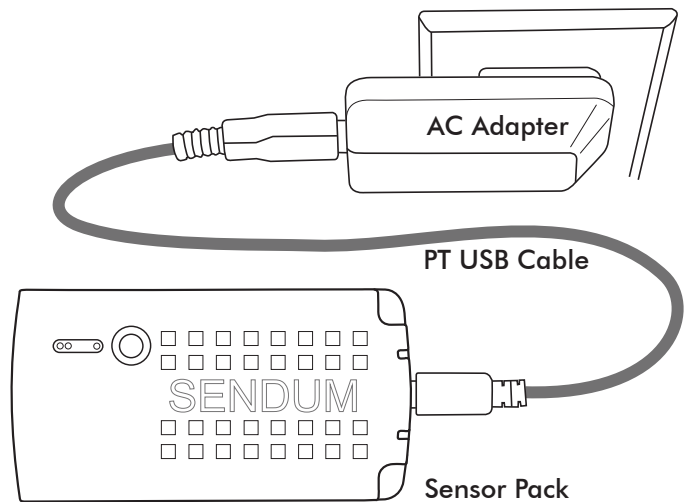

Figure 3 - Charging up a Sensor Pack

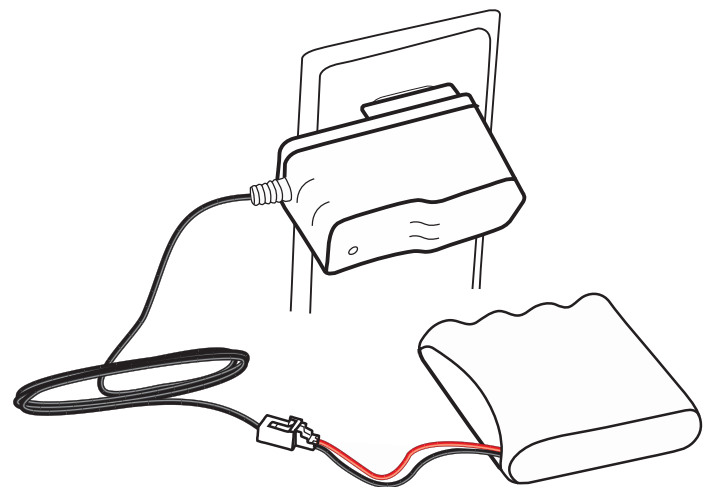

Figure 4 - Charging the 10k mAh Battery Pack

Provisioning for Sprint

The process for provisioning your device for Sprint service is simple:

- 1) Turn on your PT300D (see "1. Turning on your PT300D" on page 5). This step initiates communication with both your wireless network and with Sendum.
- 2) While communicating, both the Network and Battery LEDs should go on and off periodically. See "3. LED Lights and Status Button" on page 6
- 3) When complete (about a minute), both Network and Battery lights will go solid green (indicating success).
- 4) Unplug the PT300D Command Module from your pack. This ensures the device is power-cycled, a necessary step before the device can be operational.
- 5) The final step to provisioning is to make at least one configuration change for your device. Please refer to "Step 5 - Web Access" and "Step 6 - Configure".



You can also learn the Provisioning process by watching our video at www.sendum.com/pt300av



When speaking with your Sprint rep, please ask for and record the "IP address" and the "Port Number" for their "PDE Service". This allows your device to take advantage of network-assisted location fixes. Then send this information to support@sendum.com, complete with your name and Device Identifier.

Step 4 - Provision

If you already have your airtime account set up, then your next step depends on which wireless service you are activated under.

- If you have an active Sprint account in place, then your device will require a process called "provisioning" before it can be operational (see below).



Provisioning is a one-time, secure, and anonymous process in which your PT300D links with both your mobile network and your software web application to communicate registration information and initiate operation of the device.

- If you have an active Vodafone account in place (or you ordered it through Sendum), then your device is ready for operation when you turn it on (see "1. Turning on your PT300D" on page 5). The next step for you will be to log into Sendum's web portal (see "Step 5 - Web Access").

Step 5 - Web Access

- 1) Once you have an airtime account in place and with your device successfully provisioned, please open up your web browser and go to Sendum's web portal (called Findum™) at findum.sendum.com
- 2) If you already have a Findum account in place and you ordered your new product with the same email address, your new PT300D device will have been automatically added to your existing account. Just log in using that email address and your existing password.
- 3) If you are new to Findum, a new Findum account would have been created for you as a part of the purchase process. The username for this new account is the email address that you used, or specified, during purchasing. To obtain a password for this account, please go to findum.sendum.com and click the "Forgot your Password" link. Then just log into Findum using your email address and your new password. For a demo of this process, please visit www.sendum.com/getpassword

Step 6 - Configure

For complete information and tutorials on how to use your PT300D trackers within Findum, please refer to the detailed Findum Help Guide. Once you are logged into Findum, the guide is accessible by clicking the Help link in the upper left hand corner of any Findum page.

Note that when first get your new tracker, you will have to configure your device with an Assisted Location, Autonomous Location, or Sensor Reports interval before the device will report data.

To access the Device Configuration page within Findum, click the Devices menu item on the left side, choose your device, then click the Configuration tab.

Step 7 - View your Data

Once your PT300D has been configured, you will be able to track location, gather data, and view reports.

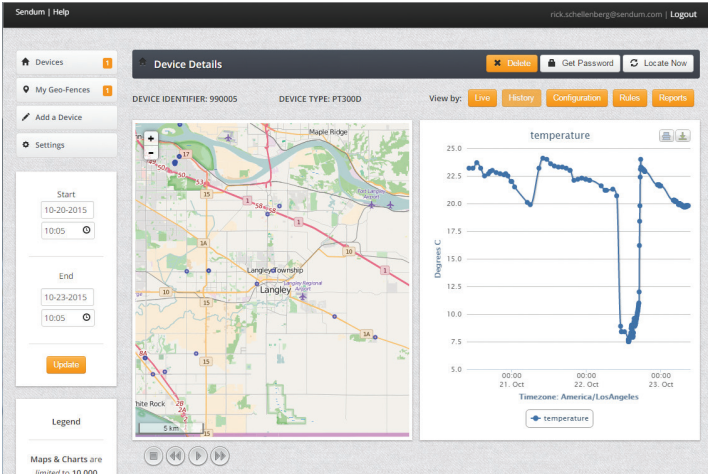

Figure 5 - Viewing Device Data in Findum

Appendix

1. Turning on your PT300D

You can turn on (i.e. power up) your PT300D by connecting the command module to a Sensor or Accessory Pack.

To make the connection, simply push the command module into the pack until you hear a click sound. Once connected, ensure the Charger LED is ON. The color will be either red or green.

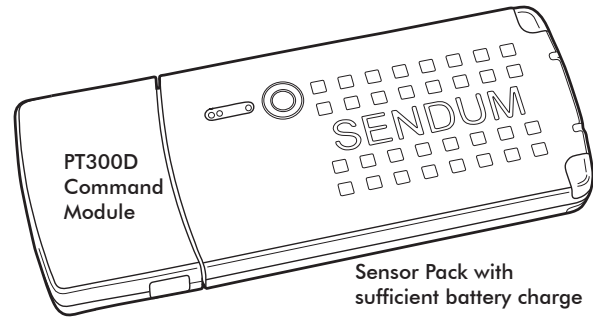
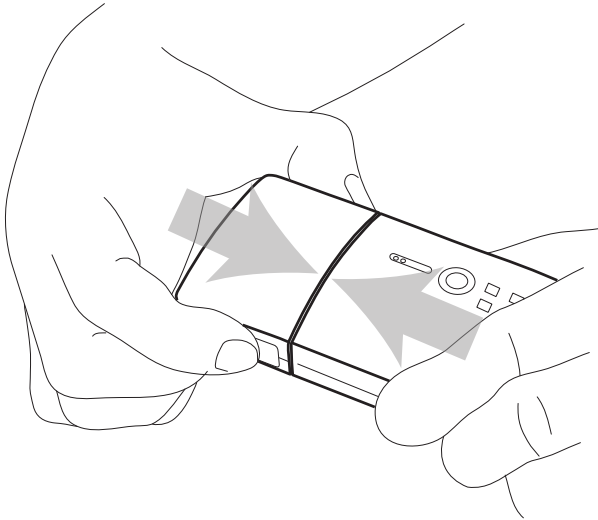

Figure 6 - Turning the PT300D on by connecting it with a charged Sensor Pack

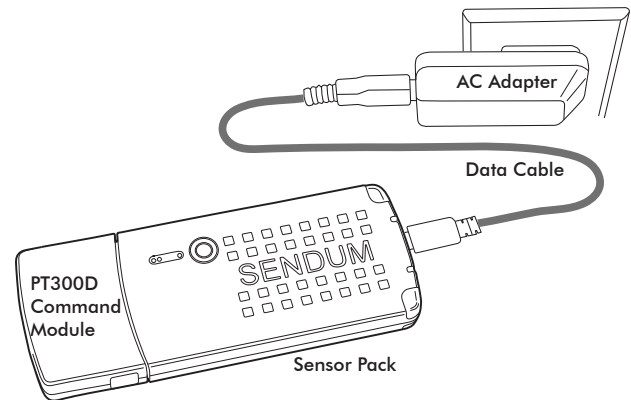



Figure 7 - Turning the PT300D on by connecting it with a Sensor Pack being charged

 **When connecting any type of Sensor or Accessory Pack to the Command Module, always make sure the connection is solid and that you hear the confirming "Click" sound.**

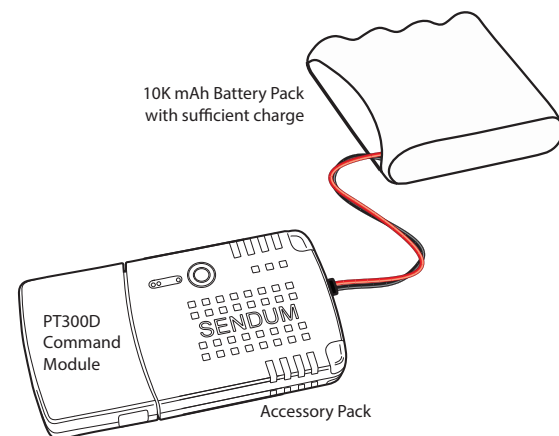
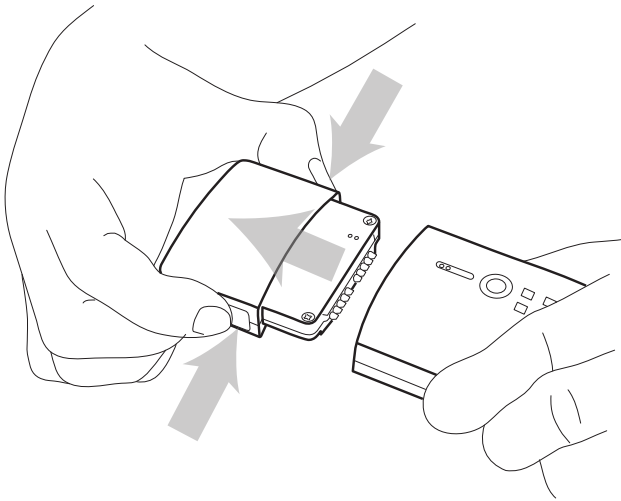

Figure 8 - Turning the PT300D on by connecting it with an Accessory Pack and a charged 10K mAH Battery Pack

2. Turning off your PT300D

To turn off (or power down) your PT300D, simply unplug the PT300D Command Module from your Sensor or Accessory Pack.

To do this, squeeze the two tabs on the side of the command module, then pull the module straight out of the pack.



3. LED Lights and Status Button

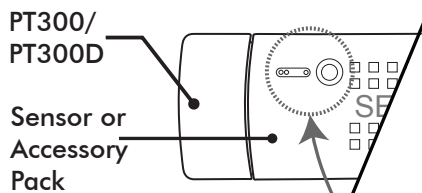

LED Indicators:

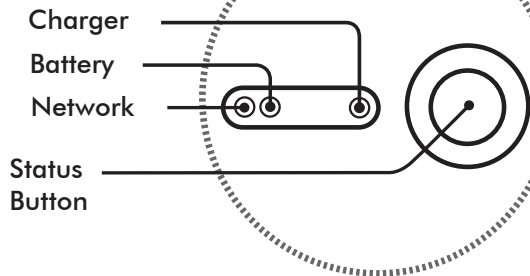

4. LED Light Indications

LED	Status	Description
Network	Solid Green	Device in carrier coverage area
	Green (Blinking)	Device is in Aircraft Transmission Suppression Mode
	Solid Red	Device out of carrier coverage area
	Red (Blinking)	Device is in Coverage Sleep Mode
Battery	Solid Green	Sensor Pack charge level near full (>80% of labeled capacity)
	Red (Blinking)	Sensor Pack charge level good (approximately 25-80% of labeled capacity)
	Solid Red	Sensor Pack needs recharging (<25% of labeled capacity)
Charger	Red	Sensor Pack is charging
	Green	Sensor Pack charging is complete